**For models with connectors SMA, QMA, SMA 2.9, Din 1.6/5.6**

Model	Type	Options	Number of positions	RADIALL part number
R573 series	All	2 & 8	3 to 6	<b>R599920000</b>
R573 series	4,5,8 & 9	All		
R574 series	All	All		
R573 series	All	All	7 & 8	<b>R599920000</b>
R574 series	All	All	7 & 8	<b>R599920000</b>
R573 series	All	All	9 & 10	<b>R599921000</b>
R574 series	All	All	9 & 10	<b>R599921000</b>
R573 series	All	All	11 & 12	<b>R599922000</b>
R574 series	All	All	11 & 12	<b>R599922000</b>

**For models with connectors N, TNC, BNC**

Model	Type	Options	Number of positions	RADIALL part number
R573 series	All	All	3 to 6*	<b>R599921000</b>
R574 series				

\* For 7 to 12 positions models, brackets are not available.

CREATION					
N°:					RADIALL 101, rue P. Hoffmann 93116 ROSNY/BOIS FRANCE Tel : (33) 0149353535 Fax : (33) 0148546363
PEN/EP : 05112					
Name: LAURENT J					
Date:15.Dec.05					
Appr.:GONIN P	Issue	Revisions	Name	Appr.	

Title : MOUNTING BRACKET FOR SPnT

Issue  
15.Dec.05Page  
2/2

Options:

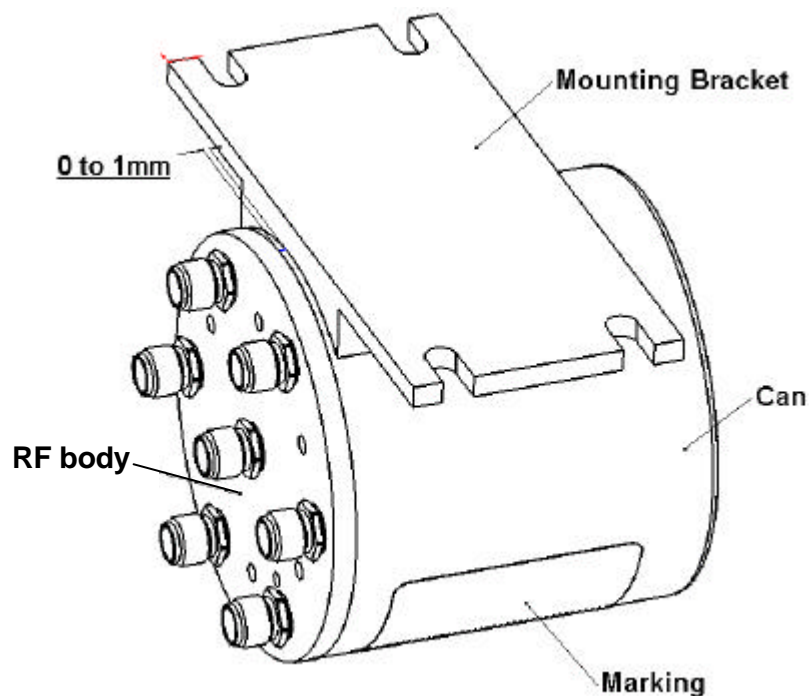
**ADHESIVE BONDING PROCESS**

- 1) Clean the can with alcohol ( Isopropanol or Ethanol).
- 2) Remove the protective adhesive tape surface.
- 3) Glue the mounting bracket **ONLY** on the blue can and **NOT** on the RF body.  
**DO NOT** glue mounting bracket on the marking (See drawing).
- 4) Firmly press the mounting bracket against the can, and maintain pressure for several seconds ( 10 seconds min) then, unit is now properly bonded (See note 1 & 2).
- 5) Product can be fixed in your equipment with four screws ( non included).

Note 1: Adhesive tape may not be used more than one time.

Note 2: Adhesive bonding does not require polymerization.